



# Volare

Pizza gas oven with **dual rotating ceramic decks**



 **SIERRA**  
range





# Volare

Pizza gas oven with  
**dual rotating ceramic decks**



Still deciding between a conveyor oven and a traditional deck oven? Look no further!  
**SIERRA brings you both.**



## Introducing . . . the revolutionary volare gas pizza oven

Features dual electrically-powered rotating **ceramic decks** with an all-stainless steel construction - this professional oven highlights accomplished engineering and inspires cooking perfection. Designed for multiple applications including **pizzerias, restaurants, airports, hotels, bistros, markets, and schools**, this 82,000 BTU oven can bake up to **160 medium-sized (12") pies** per hour while staying true to the quality and taste desired and keeping up to your highest demands.



DIGITAL TEMPERATURE DISPLAY

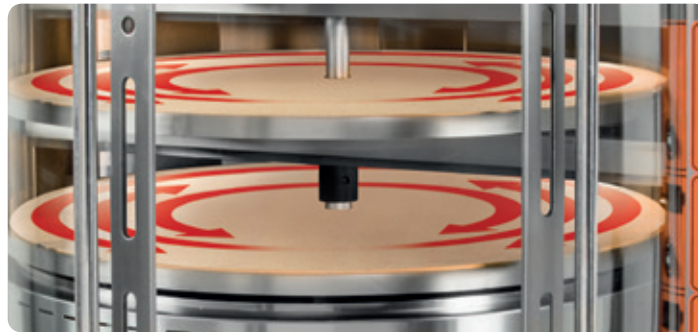

THREE WAY TEMPERED GLASS  
DOOR SYSTEM



FULL STAINLESS STEEL  
CONSTRUCTION WITH  
CHIMNEY FLUE

Both decks are individually controlled by our patented heat transfer system providing consistent results time after time (lower heat is transmitted by induction while the upper heat is transmitted by radiation).

Safety is of utmost importance to us and to our customers. We designed our heat transfer system to allow for complete and secure combustion with ultra low emissions of nitrogen oxide (NOx). This process is constantly monitored through thermocouples that interrupt the gas supply to the burners in any case of failure. The oven's ceramic decks allow chefs to place food directly on their surfaces, while the large heat-resistant front glass opening grants easy accessibility and ability to monitor cooking accuracy. The front panel features dual-temperature display, an ON/OFF switch to control deck rotations, an emergency stop button, and separate switches for each burner to control the flow of gas and easily manage operations. **The oven has been certified to meet all electrical, safety and sanitation standards of the North American market.**

Admired for its stunning appearance, performance and style, the **Volare** oven showcases a concept so far unparalleled in the foodservice industry. **Guaranteed to bring your customers back for a second and third look and another meal!**

For the operator, you can embrace a return to cooking in confidence.



16 pies



12 pies

# IPA EXPORT





# Volare

Volare	
Maximum output	84,000 BTU total
Burners	3
Electrical requirement	115/60/1 12 A
Stone deck diameter	38.6" / 980 mm
External dimensions	50.5" W / 1280 mm W
	43.0" D / 2170 mm D
	65.8" H with base / 1670 mm H with base
Net weight	550 lbs. / 250 kg
Shipping dimensions	60" W / 1525 mm W
	53" D / 1345 mm Dw2000
	79" H / mm H
Shipping weight	650 lbs. / 295 kg

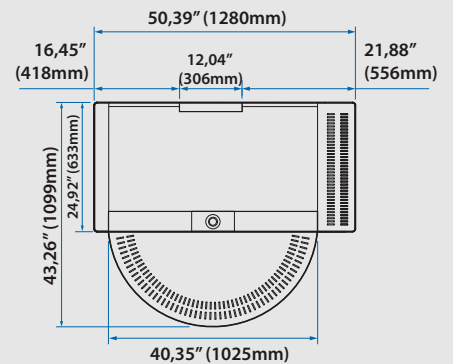
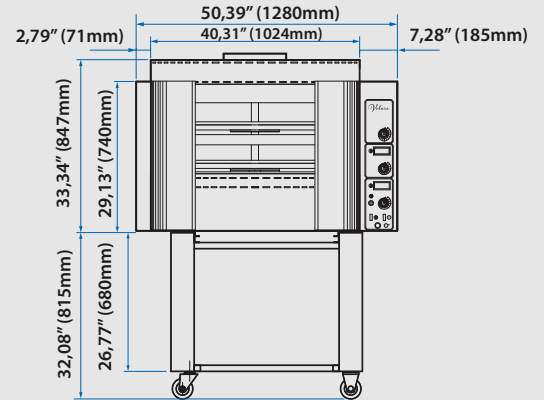

Pizza baking capacity	Size	Capacity
	Ø 12"	16 pies 144-160/h
	Ø 14"	12 pies 120-144/h



**Warranty:** 12 months parts & labor.

**Gas Connection:** 3/4" NPT on the right hand rear of the appliance. The pressure regulator (supplied) is to be connected here by the installer.

**Electrical Requirement:** 120 Volts AC, 7.9 amps per oven

**Gas pressure:** 4" W.C. - Natural Gas | 10" W.C. - Propane

**Combustible Clearances:** For use in non-combustible locations | Non-combustible Clearances: 0 inches sides, 0 inches rear

Specify type of gas and altitude, if over 2,000 feet, when ordering.

A restraining kit is required for ovens installed with a caster kit. Check your local code.



# IPA EXPORT

The Caribbean's Primary Source for Hotel, Restaurant & Laundry Equipment/Supplies

3770 S.W. 30th Avenue | Tel: (954) 581-6620 | info@ipaexport.com  
Fort Lauderdale, FL 33312 | Fax: (954) 581-6665 | www.ipaexport.com